

Installation Instructions for 52200 & 52201 Oil Breather Tank with Jeg's "Just-Able" Integral Mounting System

The JEG'S "Just-Able" mounting system is extremely easy to use.

1. Simply drill two 1/4" holes with clearance. Use a letter "F" drill bit (0.2570") or 17/64" drill bit (0.2656") in your selected mounting position. Do not drill the mounting holes closer than 1" centers or further apart than 5" centers or if you prefer we offer an optional mounting T-Bracket designed for this JEGS "product": # 555-51133 Clear Anodized or # 555-51134 Polished.
2. Place one each of the stainless steel lock and flat washers onto the stainless steel bolt and insert the assembly through the drilled hole. Start a stainless steel nut onto the bolt and repeat for the second mounting hole.
3. Install the breather by sliding it over the exposed tube boss on the top of the tank. Tighten the band clamp until the breather is secure. Install plug and straight adapter in to the threaded cross tube in the side of the tank. The fittings are interchangeable from side to side so install in desired configuration. Install the drain petcock in the bottom of the tank prior to mounting.
4. Slide the oil breather tank mounting slot over the exposed nuts (Suggestion: spray a light coating of silicone or equivalent product on the surface of the nut or bolt head to aid in the installation) and position the oil breather tank in the desired location and tighten the bolts.
5. Optional: You can also mount the bolts in the reverse direction with the head of the bolt in the "Just-Able" slot.
6. Attach the fitting on the side of the tank to desired crank case ventilation location.

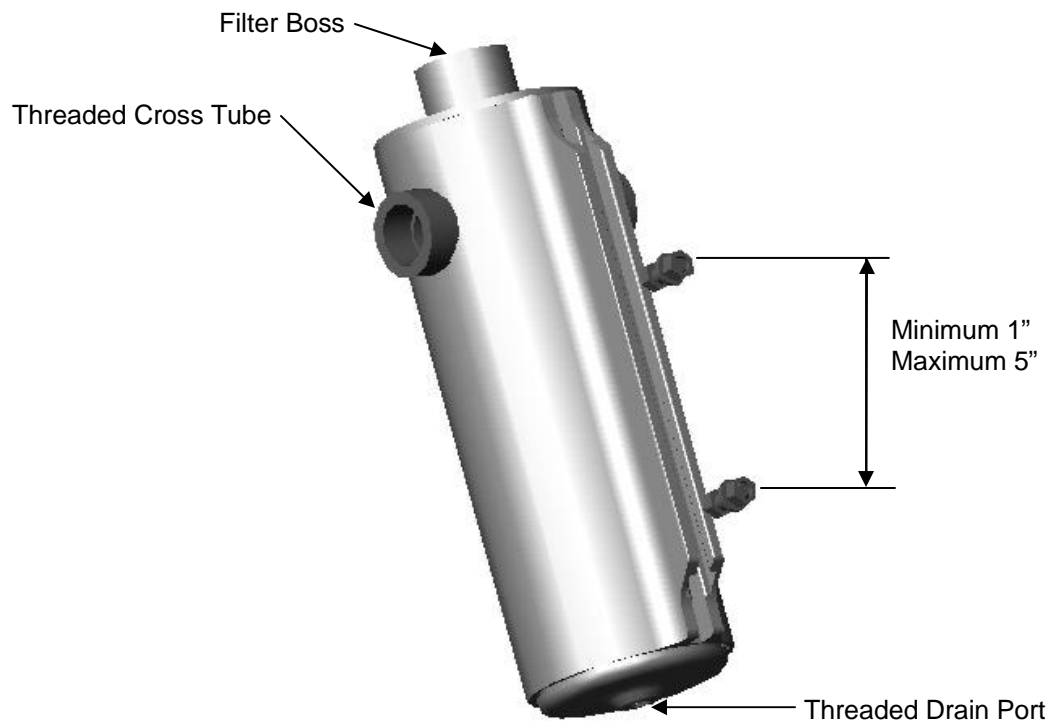

1-800-345-4545 jeps.com